

---

## **Redesign of Production Floor Layout Using Systematic Layout Planning (SLP) Method**

---

Mahesa Yudha Erdiansyah<sup>1</sup>, Joumil Aidil SZS<sup>2</sup>

***Abstract:***

*PT XYZ is a manufacturing company engaged in printing and packaging, one of their products is wafer roll packaging. The problem that occurs in this company is the lack of consideration of the degree of nearness at work stations, the placement of work stations that are not in the sequence of the production process that causes backtracking. This research used Systematic Layout Planning (SLP) method and Blocplan Software to determine the layout redesign on production floor. From the research that was conducted, layout 4 was obtained as the best proposed layout with an R score of 0.88 and several changes were made to the position of the work station placement. The proposed layout obtained a total distance between work stations of 426 meters from the total distance between work stations of the initial layout that was 670 meters, which obtained a difference of total distance from work stations between initial layout and proposed layout was 244 meters.*

***Keywords:*** Floor Layout, Systematic Layout Planning, Manufacturing

Submitted: 16 May 2024, Accepted: 10 June 2024, Published: 27 June 2024

### **1. Introduction**

The industrial sector worldwide is rapidly developing, compelling companies to continuously innovate to survive and remain competitive. One common issue that arises within companies is related to the production process, specifically in the arrangement of facility layouts. Poor layout design can lead to disordered material flow, causing excessive movement and transportation, which in turn results in suboptimal performance levels. PT XYZ, a company engaged in printing and packaging, manufactures wafer roll packaging. The wafer roll production process at PT XYZ has encountered issues due to insufficient consideration of the proximity between workstations. This has led to excessive transportation and backtracking, particularly between workstations C1 to D, C2 to D, and D to F. Consequently, it is essential to redesign the production floor layout using the Systematic Layout Planning (SLP) method to develop the best layout alternatives and minimize material movement on the production floor.

Several studies have emphasized the importance of effective layout planning in improving production efficiency. Ali Naqvi et al. (2016) highlighted that productivity

---

<sup>1</sup>Universitas Pembangunan Nasional "Veteran" Jawa Timur, Indonesia.  
mahesayudha23@gmail.com

<sup>2</sup>Universitas Pembangunan Nasional "Veteran" Jawa Timur, Indonesia.  
joumilaidil.ti@upnjatim.ac.id

improvement in a manufacturing facility can be significantly achieved using the SLP method. Gozali et al. (2020) applied the SLP method to plan the new factory layout of PT Hartekprima Listrindo, demonstrating its effectiveness in optimizing space utilization and workflow. Similarly, Haryanto et al. (2021) conducted a case study on a manufacturing company, showing that SLP can significantly enhance facility layout and operational efficiency.

Other notable studies include Haekal and Adi (2020), who explored the planning of production facilities layouts in home industries using SLP, and Islam et al. (2017), who demonstrated that applying SLP can lead to substantial productivity improvements. Jain and Yadav (2017) reviewed the approach of SLP in pulse processing mills, confirming its positive impact on layout optimization.

Despite the extensive research on the benefits of SLP in various industries, there is a noticeable gap in studies focusing on its application in the printing and packaging sector, particularly for wafer roll packaging production. While previous studies have generally shown the effectiveness of SLP in improving facility layout and productivity, specific insights into the unique challenges and requirements of the printing and packaging industry remain underexplored.

This study aims to bridge the research gap by applying the SLP method to redesign the production floor layout of PT XYZ, a company in the printing and packaging sector. The novelty of this research lies in its focus on optimizing the layout for wafer roll packaging production, a niche yet crucial segment of the industry. By addressing the specific issues of workstation proximity and excessive transportation, this study seeks to provide tailored solutions that enhance operational efficiency and performance.

The urgency of this research is underscored by the need for PT XYZ to remain competitive in a rapidly evolving industrial landscape. Optimizing the production floor layout is critical for reducing unnecessary material movement, minimizing backtracking, and ultimately improving overall productivity. As the company strives to enhance its operational efficiency, the findings of this study will be instrumental in guiding strategic layout decisions that support sustained growth and competitiveness.

## **2. Theoretical Background**

### **Systematic Layout Planning (SLP)**

Systematic Layout Planning (SLP) is a structured and organized method for layout planning developed by Richard Muther in 1973. SLP is widely applied to various problems, including production, transportation, warehousing, supporting services, assembly, office activities, and others. By measuring and designing facility layouts using SLP in a company, it can significantly increase production efficiency and improve production flow.

According to Potadar and Kadam (2019), the stages of the procedure for determining the Systematic Layout Planning (SLP) method are as follows:

1. **Collecting Data and Analyzing Material Flow:** This stage involves gathering data on material movements and analyzing quantitative measurements for each material movement between departments or operational activities. This helps in understanding the current flow and identifying areas for improvement.
2. **Analyzing the Activity Relationship:** This step determines the cost of moving materials, providing quantitative data while the analysis remains more qualitative in layout design. The Activity Relationship Chart (ARC) is used to map out the relationships between different activities.
3. **Creating a Room Relationship Diagram:** Based on the activity relationship analysis, a diagram is created to visualize the spatial relationships between different rooms or areas.
4. **Calculating the Area Requirement:** This step involves determining the space needed for each activity or department, ensuring that the layout can accommodate all necessary operations.
5. **Formulating Alternative Block Layouts:** Finally, different layout alternatives are generated and evaluated to select the most efficient and effective design.

### **Application of SLP in Various Studies**

Several studies have demonstrated the effectiveness of the SLP method in optimizing facility layouts and improving productivity. Ali Naqvi et al. (2016) showed that the application of SLP in a manufacturing facility led to significant productivity improvements. They highlighted the method's ability to streamline processes and enhance material flow, contributing to overall operational efficiency.

Gozali et al. (2020) applied SLP to plan the new factory layout of PT Hartekprima Listrindo. Their study demonstrated how SLP could optimize space utilization and workflow, leading to better operational performance. Similarly, Haryanto et al. (2021) conducted a case study on a manufacturing company, showing that SLP could significantly enhance facility layout and operational efficiency.

Haekal and Adi (2020) explored the planning of production facilities layouts in home industries using SLP. Their study underscored the method's versatility and effectiveness in different industrial contexts. Islam et al. (2017) also demonstrated substantial productivity improvements through the application of SLP, highlighting its broad applicability across various sectors.

### **3. Methodology**

The data analysis in this research employed the Systematic Layout Planning (SLP) method. The SLP method procedure consists of three stages: the analysis stage, the identification stage, and the evaluation stage.

In the **analysis stage**, the initial layout of the production floor was examined to identify inefficiencies. This involved collecting and analyzing data related to the

production machines, including their dimensions and operational specifications, as well as measuring the distances between various workstations to understand the current material flow. Additionally, available workspace data was assessed to identify potential areas for improvement. An Activity Relationship Chart (ARC) was developed to map out the relationships between different activities and workstations.

The **identification stage** focused on identifying the material flow that occurs at each workstation. This involved observing the initial layout and measuring the rectilinear distances to determine the total distance of material movement. This analysis helped in understanding how materials move through the production floor and identifying areas where improvements could be made to reduce unnecessary movement and increase efficiency.

In the **evaluation stage**, the proposed layout design was developed using the insights gained from the previous stages. This involved further refining the Activity Relationship Chart (ARC) and creating a detailed Activity Relationship Diagram (ARD). The proposed layout design was then evaluated and optimized using Blocplan software to ensure the most efficient arrangement of workstations and equipment.

By following these stages, the research aimed to redesign the production floor layout of PT XYZ to enhance operational efficiency and reduce material movement.

#### 4. Empirical Findings/Result

##### A. Data Collection

##### 1) Initial Layout

The initial layout is a layout illustration adjusted to the current layout at PT XYZ. The initial layout can be seen in the following figure:

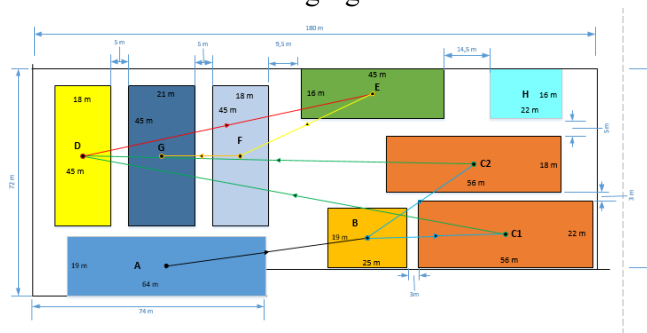

Figure 1. Initial Layout

##### 2) Areas of Workstation

The workstation area on the production floor of PT. XYZ can be seen in the following table :

**Table 1. Production Floor Area**

No.	Available Workstations	Code	Length (m)	Width (m)	Area (m <sup>2</sup> )
1	Raw Material Warehouse	A	64	19	1.216
2	Cutting Workstation	B	25	19	475
3	Printing Workstation 1	C1	56	22	1.232
4	Printing Workstation 2	C2	56	18	1.008
5	UV Workstation	D	45	18	810
6	Pond Workstation	E	45	16	720
7	Gluing Workstasion	F	45	18	810
8	Sorting Workstation	G	45	21	945
9	Laminating Workstation	H	22	16	352
TOTAL					7568

**3) Calculation of Distance between Workstation Initial Layout**

PT XYZ has 9 work stations. The following is the calculation of the distance between the initial layout workstations needed to redesign the layout and reduce the distance to increase production effectiveness.

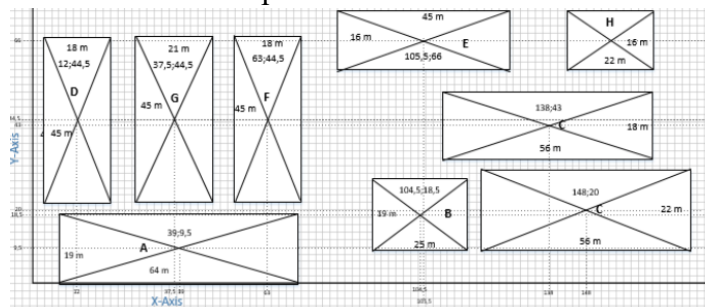

**Figure 2. Initial Layout Rectilinear Distance Calculation**

Work station distance A– B

$$\begin{aligned}
 D_{AG} &= |X_A - X_B| + |Y_A - Y_B| \\
 &= |39 - 104,5| + |9,5 - 18,5| \\
 &= |65,5| + |9| \\
 &= 74,5 \text{ m}
 \end{aligned}$$

**Table 2. Distance Between Work Stations Initial Layout**

No.	From	To	Distance (m)
1	A	B	74,5
2	B	C1	45
3	B	C2	58
4	C1	D	160,5
5	C2	D	127,5
6	D	E	115
7	E	F	64
8	F	G	25,5
TOTAL			670

For the production process of wafer roll packaging products, there are 8 workstation movements. The total movement distance of the initial layout is 670 meters.

**B. Data Processing**

**1) Activity Relationship Chart (ARC)**

Activity Relationship Chart Production workstations are used to represent the proximity relationship of each department at the production process workstation. The explanation for determining the Activity Relationship Chart (ARC) is as follows:

1. Workstation relationship that has code A means absolute necessary nearness.
2. Workstation relationships that has code E means especially important to be near
3. Workstation relationships that has code I, means important to be near
4. Workstation relationships that has code O, means ordinary nearness.
5. Workstation relationships that has Code U, means unnecessary nearness,
6. Workstation relationships that has an X code, means undesirable to be near.

This can be seen in the following figure:

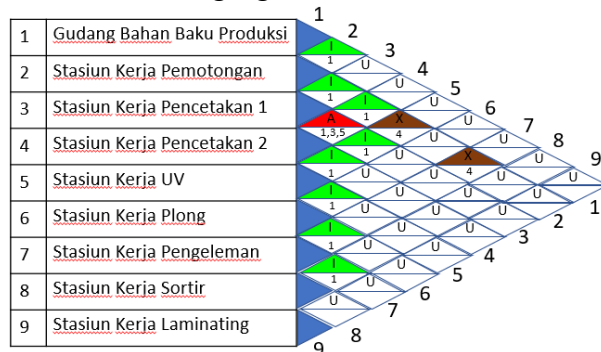

**Figure 3. Activity Relationship Chart**

**Table 3. Degree of Nearness**

Degree of Nearness Symbol	Description	Color Code
Red Color	Absolutely important	A
Orange Color	Especially Important	E
Green Color	Important	I
Blue Color	Ordinary Nearness	O
White Color	Unimportant	U
Brown Color	Undesireable	X

**2) Activity Relationship Diagram (ARD)**

This stage is carried out by filling in the worksheet used to explain the results of the activity relationship chart (ARC) relationship map that aims to facilitate the creation of activity relationship diagrams (ARD).

**Table 4. Worksheet Table**

No.	Workstation	Degree of Nearness					
		A	E	I	O	U	X
1.	Raw Material Warehouse			2		3,4,5,6,7,8,9	
2.	Cutting Workstation			3,4		1,6,7, 8,9	5,7
3.	Printing Workstation 1	4		5		1,2,6,7,8,9	
4.	Printing Workstation 2	3		5		1,2,6,7,8,9	
5.	UV Workstation			6		1,3,4,7,8,9	2
6.	Pond Workstation			7		1,2,3,4,5,8,9	
7.	Gluing Workstasion			8		1,3,4,5,6,8,9	2
8.	Sorting Workstation					1,2,3,4,5,6,7,9	
9.	Laminating Workstation					1,2,3,4,5,6,7,8	

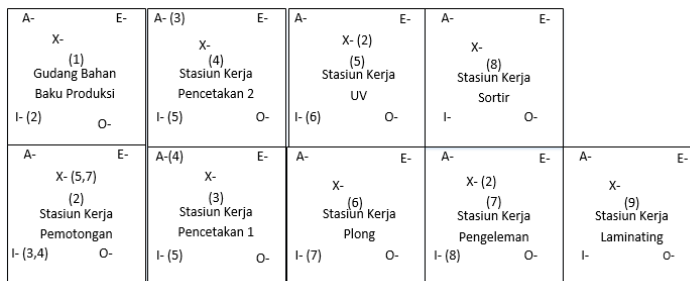

**Figure 4. Block Template**

Block template is a recapitulation of the degree of relationship between workstations that included in the block that represents a facility, the aim is to facilitate the identification of relationships between workstations. Production Raw Material Warehouse Workstation has a degree of relationship I (important) with Cutting Workstation. Cutting Workstation has a degree of relationship I (important) with Printing Workstation 1 and Printing Workstation 2 and has a degree of relationship x (very unimportant / should not be close) with UV Workstation and Welding Workstation. Printing workstation 1 has a degree of relationship A (Absolute nearness) with printing workstation 2 and has a degree of relationship I (important) with UV workstation. Printing workstation 2 has a degree of relationship A (Absolute nearness) with printing workstation 1 and has a degree of relationship I (important) with the

UV work station. UV workstation has a degree of relationship I (important) with Pond Workstation and has a degree of relationship x (very unimportant/should not be brought closer) with Cutting Workstation. Pond Workstation has a degree of relationship I (important) with Gluing workstation. The gluing workstation has a degree of relationship I (important) with Sorting Workstation and has a degree of relationship x (very unimportant/should not be near) with Cutting Workstation.

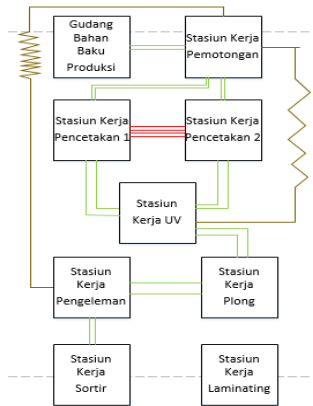

Figure 5. Activity Relationship Diagram

Table 5. ARD Description

Degree of Nearness	Description	Line Code	Ilustration	Color
A	Absolutely important	4 Lines		Red
E	Especially Important	3 Lines		Gold
I	Important	2 Lines		Green
O	Ordinary Nearness	1 Line		Blue
U	Unimportant	No Line	-	-
X	Undesireable	Wavy Line		Orange

### 3) Designing a Proposed Layout Using Blocplan Software

In Blocplan Software, the input used is the area of each production facility and the Activity Relationship chart (ARC). After the data is completed, the Blocplan Software will automatically iterate to get the best layout.

1. Input the name and area of the workstation layout to be processed



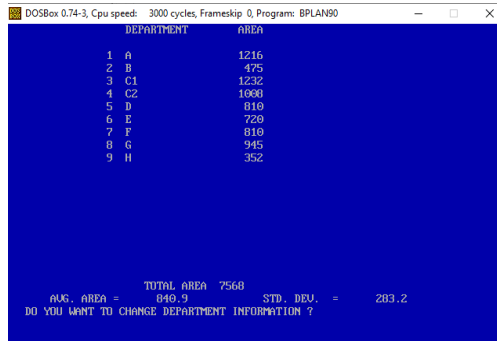

Figure 6. Input Name and Area

2. Activity Relationship Chart

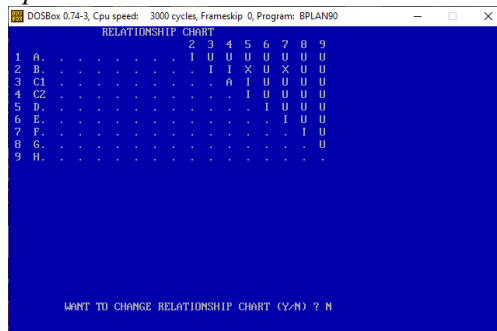

Figure 7. Input Activity Relationship Chart

3. Iteration Results

Table 6. Random Layout

Layout	Adj Score	R-score	Rel-dist Score
1	1,00 - 1	0,76 - 3	-664 - 6
2	0,92 - 3	0,77 - 2	-813 - 3
3	0,85 - 9	0,51 - 10	255 - 10
4	1,00 - 1	0,88 - 1	-1200 - 1
5	0,92 - 3	0,67 - 8	-340 - 8
6	0,92 - 3	0,76 - 4	-848 - 2
7	0,92 - 3	0,74 - 7	-674 - 5
8	0,92 - 3	0,75 - 5	-734 - 4
9	0,92 - 3	0,75 - 6	-627 - 7
10	0,85 - 9	0,58 - 9	-67 - 9

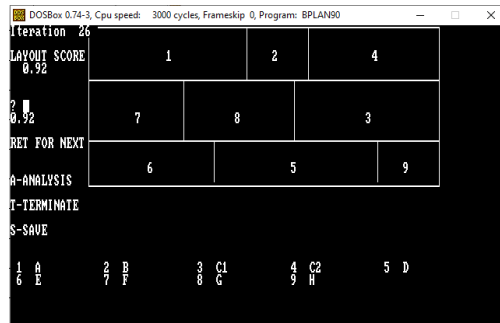

Figure 8. Proposed Layout from Bloclan Software

From the results of 10 iterations that have been carried out by Bloclan Software, the best layout is the layout that has an R- Score value closest to 1. The layout that has an R- Score value closest to 1 is layout 4 with an R-score value of 0.88, it means that the layout is the most efficient layout and fulfills the proposed layout.

C. Design of Proposed Layout

To make a layout proposal that can be implemented at PT XYZ, it is important to re-adjust the proposed layout of bloclan software to the actual dimensions of the facility.

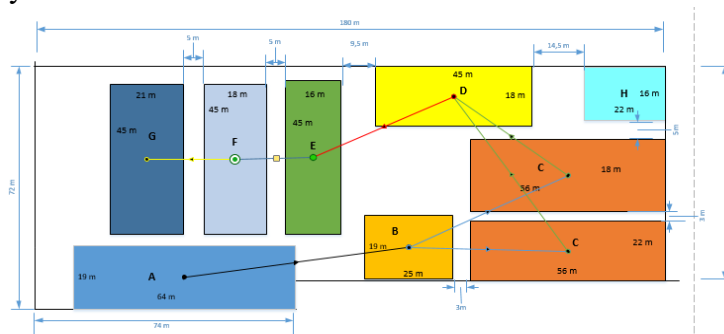

Figure 9. Proposed Layout

D. Calculation of Distance between workstations of proposed layout

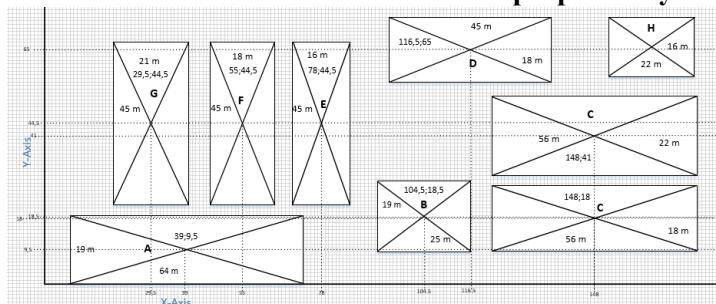

Figure 10. Calculation of Rectilinear Distance of Proposed Layout

**Table 7. Distance Between Work Stations Proposed Layout**

No.	From	To	Distance (m)
1	A	B	74,5
2	B	C1	66
3	B	C2	44
4	C1	D	55,5
5	C2	D	78,5
6	D	E	59
7	E	F	23
8	F	G	25,5
TOTAL			426

In the production process there are 8 workstation movements, the total distance between workstations for the proposed layout is 426 meters.

**E. Comparison of distance between work stations proposed layout and initial layout**

**Table 8. Comparison of Distance between Workstations Proposed Layout and Initial Layout**

No	From	To	Initial Layout	Proposed Layout	Difference
1	A	B	74,5	74,5	0
2	B	C1	45	66	-21
3	B	C2	58	44	14
4	C1	D	160,5	55,5	105
5	C2	D	127,5	78,5	49
6	D	E	115	59	56
7	E	F	64	23	41
8	F	G	25,5	25,5	0
			670	426	244

From the table above, it can be determined that the difference in the longest distance is at Printing 1 work station (C1) to UV work station (D) which is 105 m and at Cutting Work Station (B) to the Printing 1 Work Station (C1) there is an increase in distance of 21 m. The total distance between work stations in the initial layout is 670 m while the total distance between work stations in the proposed layout is 426 m and the difference in distance between the initial layout and the proposed layout is 244 m, it can be seen that there is a reduction in the distance traveled by the material in the proposed layout, so that the proposed layout is accepted and will be recommended to the company.

**5. Discussion**

The initial layout is a visual representation of the current production floor at PT XYZ, highlighting the arrangement of various workstations and the material flow between

them. This layout reveals inefficiencies in the production process, particularly related to the distances between workstations, which result in excessive material movement and backtracking. For instance, the movement from Workstation C1 to Workstation D and from Workstation C2 to Workstation D involves significant distances that contribute to inefficiencies. This layout serves as a baseline for identifying areas for improvement and redesign.

The production floor at PT XYZ consists of several workstations, each designated for specific tasks. These workstations vary in size, which influences the overall workflow and material handling within the facility. The following are the dimensions and areas of each workstation: the Raw Material Warehouse (A) measures 64m x 19m (1,216m<sup>2</sup>), the Cutting Workstation (B) is 25m x 19m (475m<sup>2</sup>), Printing Workstation 1 (C1) is 56m x 22m (1,232m<sup>2</sup>), Printing Workstation 2 (C2) is 56m x 18m (1,008m<sup>2</sup>), the UV Workstation (D) is 45m x 18m (810m<sup>2</sup>), the Pond Workstation (E) is 45m x 16m (720m<sup>2</sup>), the Gluing Workstation (F) is 45m x 18m (810m<sup>2</sup>), and the Sorting Workstation (G) is 45m x 21m.

The results of this study demonstrate that the initial layout at PT XYZ is inefficient, leading to unnecessary material movement and increased production time. These findings align with previous research, such as the study by Haryanto et al. (2021), which emphasized the importance of optimizing facility layouts to improve operational efficiency. Similarly, Naqvi et al. (2016) highlighted that poor facility layouts can lead to increased transportation costs and reduced productivity.

By implementing the Systematic Layout Planning (SLP) method, this study aims to redesign the production floor layout to minimize material movement and enhance production efficiency. Previous studies, such as those by Gozali et al. (2020) and Suhardi et al. (2019), have shown that the SLP method is effective in creating more efficient layouts by systematically analyzing material flow and activity relationships. The reduction in total material movement distance from 670 meters in the initial layout to 426 meters in the proposed layout highlights the significant improvement achieved through this method. This reduction not only decreases transportation time and costs but also streamlines the production process, leading to higher productivity and better utilization of resources.

## 6. Conclusions

The research conducted at PT XYZ concluded that layout 4, generated through Blocplan Software after 10 iterations, is the best proposed layout with an R-score value of 0.88. This layout involves significant changes, such as relocating the UV workstation closer to Printing Workstation 1 and Printing Workstation 2, and adjusting the positions of the Gluing and Sorting Workstations, thereby optimizing workflow and reducing unnecessary material movement. The total distance of movement between workstations in the initial layout was 670 meters, while the proposed layout reduces this to 426 meters, achieving a reduction of 244 meters. This demonstrates a significant

improvement in efficiency and a more streamlined production process. Future research should explore the long-term impacts of the new layout on production efficiency and worker productivity. Additionally, further studies could investigate the continuous optimization of facility layouts through advanced simulation techniques and software. Integrating other lean manufacturing principles and technologies, such as automated guided vehicles (AGVs) and real-time data analytics, could also enhance the production process and adapt to changing demands and production scales.

## References:

- Ali Naqvi, S. A., Fahad, M., Atir, M., Zubair, M., & Shehzad, M. M. (2016). Productivity improvement of a manufacturing facility using systematic layout planning. *Cogent Engineering*, 3(1), 1207296.
- Gozali, L., Widodo, L., Nasution, S. R., & Lim, N. (2020, April). Planning the New Factory Layout of PT Hartekprima Listrindo using Systematic Layout Planning (SLP) Method. In *IOP Conference Series: Materials Science and Engineering* (Vol. 847, No. 1, p. 012001). IOP Publishing.
- Haryanto, A. T., Hisjam, M., & Yew, W. K. (2021, March). Redesign of facilities layout using Systematic Layout Planning (SLP) on manufacturing company: a case study. In *IOP Conference Series: Materials Science and Engineering* (Vol. 1096, No. 1, p. 012026). IOP Publishing.
- Haekal, J., & Adi, D. (2020). Planning of production facilities layouts in home industry with the systematic layout planning method. *International Journal of Innovative Science, Engineering & Technology*, 7(10), 147-153.
- Islam, M. A., Rashed, C. A. A., & Hasan, J. (2017). Productivity improvement through the application of systematic layout planning. *Review of General Management*, 25(1), 38-54.
- Jain, S., & Yadav, T. K. (2017). Systematic layout planning: A review of improvement in approach to pulse processing mills. *International Research Journal of Engineering and Technology (IRJET)*, 4(5), 503-7.
- Khariwal, S., Kumar, P., & Bhandari, M. (2021). Layout improvement of railway workshop using systematic layout planning (SLP)—A case study. *Materials Today: Proceedings*, 44, 4065-4071.
- Lin, Q. L., Liu, H. C., Wang, D. J., & Liu, L. (2015). Integrating systematic layout planning with fuzzy constraint theory to design and optimize the facility layout for operating theatre in hospitals. *Journal of Intelligent Manufacturing*, 26, 87-95.
- Liu, H., Liu, X., Lin, L., Islam, S. M., & Xu, Y. (2020). A study of the layout planning of plant facility based on the timed Petri net and systematic layout planning. *PLoS One*, 15(9), e0239685.
- Potadar, O. V., & Kadam, G. S. (2019). Development of facility layout for medium-scale industry using systematic layout planning. In *Proceedings of International Conference on Intelligent Manufacturing and Automation: ICIMA 2018* (pp. 473-483). Springer Singapore.

- Singh, A. P., & Yilma, M. (2013, May). Production floor layout using systematic layout planning in Can manufacturing company. In *2013 International Conference on Control, Decision and Information Technologies (CoDIT)* (pp. 822-828). IEEE.
- Suhardi, B., Juwita, E., & Astuti, R. D. (2019). Facility layout improvement in sewing department with Systematic Layout planning and ergonomics approach. *Cogent Engineering*, *6*(1), 1597412.
- Suhardini, D., Septiani, W., & Fauziah, S. (2017, December). Design and simulation plant layout using systematic layout planning. In *IOP Conference Series: Materials Science and Engineering* (Vol. 277, No. 1, p. 012051). IOP Publishing.
- Watanapa, A., & Wiyaratn, W. (2012). Systematic layout planning to assist plant layout: case study pulley factory. *Applied mechanics and materials*, *110*, 3952-3956.